



5YOA B10 Access Controller

1. Specifications:

1.1 Technical parameters:

NO	Item	Value
1	Operating voltage	DC 12V±10%
2	Operating current	< 100mA
3	Dimensions	117×75×20(mm)
4	Weight	106g
5	Ambient temperature	0°C~60°C
6	Relative humidity	20%~80%
7	Storage	1000users
8	Card type (alternative)	EM(ID) card (IC card for options)
9	Card reading distance	2~10CM

1.2 Factory Default:

Programming Password	123456
Common Access Password	None
Relay Unlock output	5 Seconds
Open mode	Card or Access Password Access Password include Private Access Password (PIN) and Common Access Password
Security mode	OFF
Backlight (For options)	Auto

1.3 Light and Sound indicates:

Light: Blue and green

Light Description	Indicates
Blue light flash every 1 sec (Slow flash)	Standby state
Green light flash every 0.5sec (Fast flash)	Pending further action
Blue light is always ON	Programming state
Green light is always ON within Open Time	Unlocking state

Sound: Buzz

Sound Description	Indicates
1 short buzz	Valid input
3 short buzz	Invalid input
1 long buzz	Programming success
Continuous long buzz	Restoring factory programming passwords

2. Installations Guide:

JP1 terminal:

NO	Mark	Color	Function
1	+12V	Red	Power+
2	GND	Black	Power-
3	PUSH	Yellow	Low level output
4	BEL+	Grey	High level Input
5	BEL-	White	Voltage output
6	NC	Green	Relay NC output
7	COM	Blue	Relay Com output
8	NO	Purple	Relay NO output
9	OPEN	Orange	Door Release

Wiring diagram:

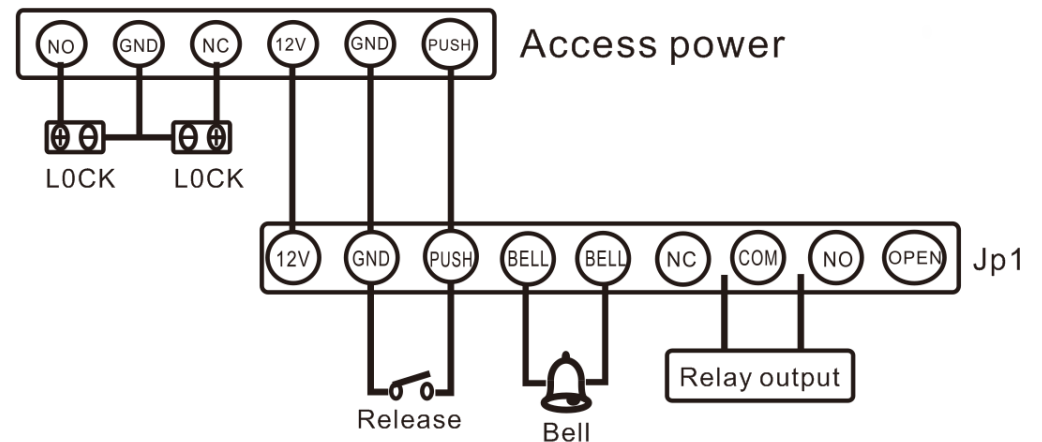

Remark: If let relay drive electric-lock, please connect a reverse diode with the lock's "+" and "-" poles.

3. Programming Guide

3.1 Detailed Programming Guide: Programming Password Default: 123456, all password can be 3~6

Purpose		Operation				Remark
Basic Function	Change Programming Password	#	Programming Password	#	0 new Programming Password # new Programming Password #	If Programming Password lost, perform 3.2 to reset to Factory Default (123456).
	Add user card	#	Programming Password	#	1 read card #	If add multi cards, read cards continuously
	Set Common Access Password	#	Programming Password	#	21 new Common Access Password #	Common Access Password is only one. Open method: Common Access Password #
	Delete all users	#	Programming Password	#	40 0000 #	Delete all cards and PIN except Common Access Password
	Delete user by read card	#	Programming Password	#	41 read card #	If delete multi cards, read cards continuously
Expand Function	Add Private Access Password(PIN)	#	Programming Password	#	22 PIN #	PIN can be more, Unlock door method: PIN #
	Add card by input card No.	#	Programming Password	#	23 input card No. #	Card No. is 10-digit or 8-digit, machine auto-identify
	Add multi-card by input card No. zone	#	Programming Password	#	24 input start card No. card Qty #	Card Qty is 4-digit (If one-time add twenty cards, input 0020)
	Add "card +PIN"	#	Programming Password	#	3 read card PIN #	If modify PIN, see 3.5
	Delete user by input User ID No.	#	Programming Password	#	42 input User ID No. #	About User ID No. see 3.4
	Delete user by input card No.	#	Programming Password	#	43 input card No. #	Card No. is 10-digit or 8-digit, machine auto-identify
	Delete user by input PIN	#	Programming Password	#	44 input PIN #	PIN is 3~6 digits.
	Delete all PIN users	#	Programming Password	#	45 1111 #	Use to PIN users (Do not include Card users and Card +PIN users)
	Change Open time	#	Programming Password	#	5 XX #	XX can be 2-digit, and the max. is 99. If input 00, the signal output time is 0.2 Secs.
	Set Open mode	#	Programming Password	#	6 XX #	XX can be 01(only card)/ 02(card or Access Password)/ 03(card+PIN)
Reset Factory Default	#	Programming Password	#	8 99 #	Except Programming Password and Manager Card	

3.2 To reset to Factory Programming Password (123456)

Step1、 Turn off power and connect bin1 of RST(S1)。

Step2、 Turn on power and buzzer gives 3 long buzz with green light flash fast。

If need to set Manager Card, now read two empty cards first one as Manager Add Card and Second one as Manager Delete Card with red light flashing and continuous short buzz .

Step3、 Turn off power, disconnect bin1 and connect bin 2 of RST.。

Step4、 Turn on power again.

3.3 How to use Manager Card – MAC&MDC

To add a card user in standby mode:

To delete a card user in standby mode:

To delete all users in standby mode:

Remark: User cards can be added or deleted continuously.

3.4 User ID No. explain

User ID is auto-generating 4-digit number started at 0001. The number increases with adding user one by one and ignores deleting user.

Common Access Password has no ID.

3.5 How to change PIN (When open mode: card+ PIN)

After reading card and input corresponding PIN to open the door, within 5 seconds, long press until the green light flash fast, and then input , new PIN changed successfully with a long buzz.